

# Bronze/Stainless Steel Body Globe Valve for Cryogenic Service

## SKB Series

### Application

The SKB Series globe valves are designed for the handling of cryogenic liquids through trailer, bulk tanks and piping configurations. Our time tested spring loaded stem packing and superior seat design provide for long life and easy maintenance. Internal components are the same for BB Series. Also available in short stem version.

### Features

- **Superior Flow:** Provides high Cv for rapid and reliable trailer and tank loading and unloading
- **Top Entry:** This valve can be permanently installed in the line and serviced from the top. Bolted bonnet style provides secure integrity
- **Soft Seated:** Conical PCTFE seat provides a bubble tight seal. Less chance of debris trapped in the seat and longer service life
- **Stem Packing:** V-Ring spring loaded packing provides extended service life without constant packing adjustment
- **Sizes:** 1/4" through 2" - (20mm through 50mm)
- **Ends:** Buttweld and Socket Weld
- **Service:** Liquefied and vaporized atmospheric gases, LNG for trailers, bulk tanks ISO containers and piping configurations
- **Temperature Rating:** -325°F to +150°F (-198°C to +65°C)
- **Pressure Rating:** (Cold, Non-Shock) 720 psig (50 barg)
- Cleaned for oxygen service per CGA G-4.1

### Materials

Body .....	Stainless Steel ASTM A351
Upper Bonnet .....	Brass ASTM B16
Lower Bonnet .....	Bronze ASTM B283
Seat Disk .....	PCTFE ASTM D1430
Seat Retainer.....	Brass ASTM B16
Stem .....	Stainless Steel ASTM A582
Spring .....	Stainless Steel ASTM A313
Packing.....	PTFE
Handwheel.....	Chromate Coated Ductile Iron ASTM A395
Bonnet Gasket.....	PTFE, 25% Glass Filled
Fasteners.....	Stainless Steel ASTM A320



SKB Series

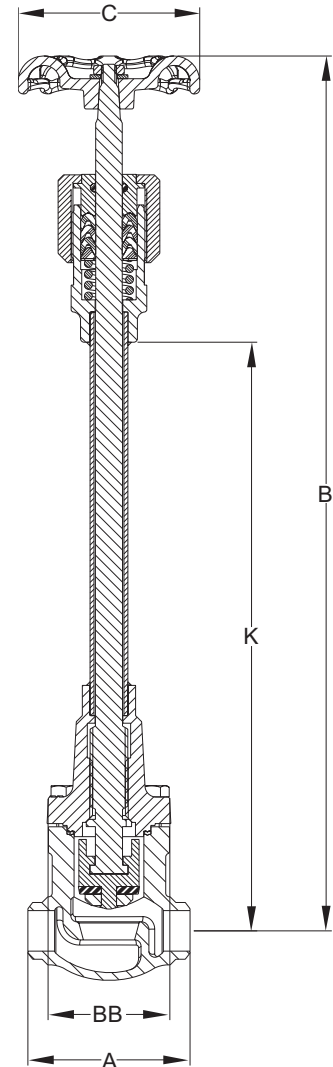

### Ordering Information

Part Number	Size Inches	Size DN	Connection	A		B		C		BB		K		Cv (Kv)
				Inches	mm	Inches	mm	Inches	mm	Inches	mm	Inches	mm	
SKB9402BW	1/4"	8	Butt Weld	2.68	68	14.4	366	3	76	2	51	9.7	246	1.7 (1.47)
SKB9402SW			Socket Weld											
SKB9404BW	1/2"	15	Butt Weld	3.62	92	14.6	371	4.75	121	3.44	87	9.3	236	28.3 (21.60)
SKB9404SW			Socket Weld											
SKB9406BW	3/4"	20	Butt Weld	5.75	146	16.21	412	5.25	133	4.06	103	9.9	251	53 (45.80)
SKB9406SW			Socket Weld											
SKB9408BW	1"	25	Butt Weld	4.75	121	14.6	371	4.75	121	3.44	87	9.3	236	28.3 (21.60)
SKB9408SW			Socket Weld											
SKB9412BW	1 1/2"	40	Butt Weld	4.75	121	14.6	371	4.75	121	3.44	87	9.3	236	28.3 (21.60)
SKB9412SW			Socket Weld											
SKB9416BW	2"	50	Butt Weld	5.75	146	16.21	412	5.25	133	4.06	103	9.9	251	53 (45.80)
SKB9416SW			Socket Weld											