

Stainless Steel Angle Globe Valves for Cryogenic Service

SKA Advantage Series

Application

RegO/Goddard stainless steel angle globe valves are designed for handling cryogenic liquids. Designed for fill manifolds applications of bulk tanks. RegO Kold-Seal™ stem seal technology assures a tight seal preventing gas loss. The conical seat design allows exceptional flow, positive shut off and less chance of debris accumulation in the flow path—resulting in an overall longer service life. Maintenance on the packing and seat is quick and easy. Ideal service medium includes oxygen, nitrogen, argon, carbon dioxide, nitrous oxide, methane, ethane, ethylene, krypton, and LNG.

Features

- Sizes: 1" through 1½"
- Connection: Socket Weld
- Service: Liquefied and vaporized atmospheric gases, LNG
- Temperature rating: -320°F to +150°F (-196°C to +65°C)
- Pressure rating: Cold, Non-Shock, 720 psig (50 barg) Class 300 (PN 50)
- Cleaned and packaged for oxygen service per CGA G-4.1
- Soft Seat: PCTFE material which is the most widely specified cryogenic seat material in the industry
- Stem Packing: Proven Kold-Seal technology, live loaded PTFE.
- Conical seat, provides more Cv
- Seat assembly without nut and washer. No loose materials from vibration. Less chance of failure
- Pressure relief system of the bonnet increases life of packing system
- Ergonomics handwheels for ease of use
- 100% factory tested. Each valve is individually bagged and boxed to arrive in factory new condition until installation

Materials

Body Stainless Steel ASTM A351 CF8
 Bonnet and Tube Stainless Steel ASTM A351 CF8/ASTM A479 type 304
 Stem Stainless Steel ASTM A582 S30300
 Spring Stainless Steel ASTM A313 S30200
 Packing Live Loaded PTFE Packing
 Gasket PTFE 25% Glass Fill
 Seat Disc PCTFE ASTM D1430
 Seat Retainer Brass ASTM B16
 Bonnet Screws ASTM F837
 Handwheel Painted Aluminum

PED Certified

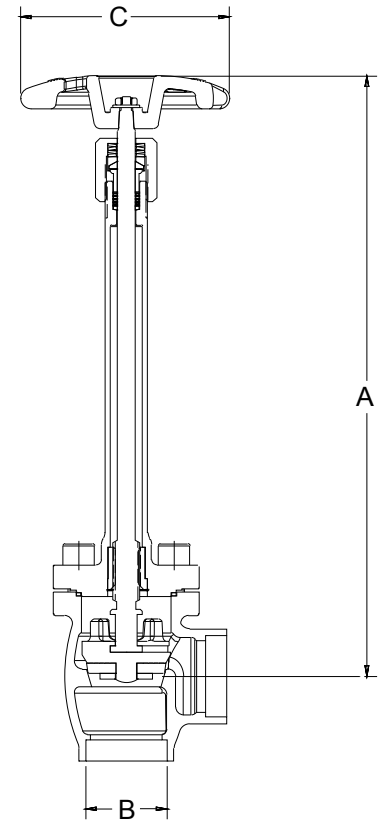

Ordering Information

Part Number	Size Inches	Size DN	Connection	A Inches	A mm	B Inches	B mm	C Inches	C mm	Weight lbs	Weight kg
SKA9408LSW	1"	25	Socket Weld	14.6	370	1.33	33.78	4	102	5.41	2.45
SKA9412LSW	1½"	40				1.92	48.77	5	127	8.85	4.01
SKA9408MSW	1"	25		10.6	270	1.33	33.78	4	102	5.0	2.2
SKA9412MSW	1½"	40				1.92	48.77	5	127	8.0	3.6