

# ASME Carbon Dioxide Relief Valves

## UA3149A Series

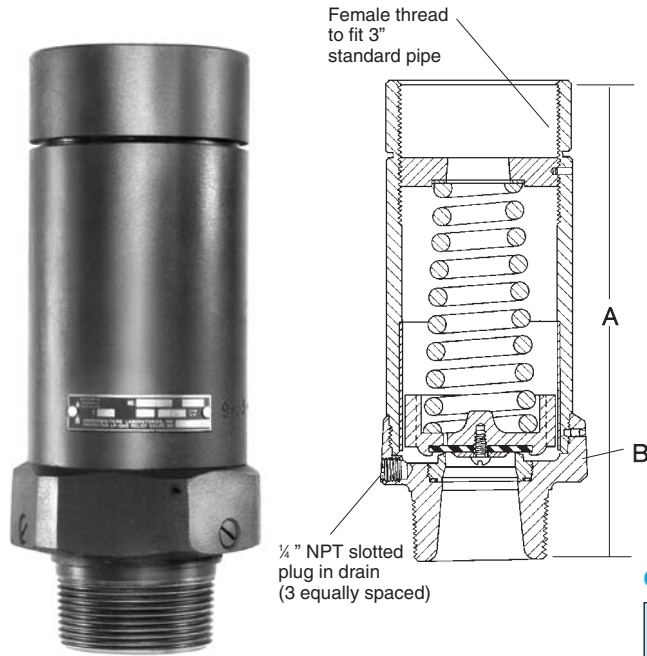

### Application

The UA3149A series “pop-type” relief valves are especially designed for use as a secondary relief valve in carbon dioxide transports and stationary storage tanks. The relief valve is designed to protect the tank from excessive over pressure in the event of fire or other emergencies. A small throttling-type primary relief valve must also be provided to control boil-off and maintain tank pressure. Provisions must be made to prevent the accumulation and build-up of water and foreign material in the valve.

### Features

- “Pop-type” design permits the relief valve to open slightly to relieve moderately excessive pressures.
- Relief valve “pops” open to full discharge capacity when pressure exceeds a predetermined point.

### Materials

Body.....Steel and Ductile Iron  
 Liner.....Stainless Steel  
 Seat Insert.....Stainless Steel  
 Spring Guide.....Brass  
 Adjusting Screw .....Ductile Iron  
 Seat Disc.....Urethane Compound  
 Spring.....Corrosion Resistant Steel

### Ordering Information

Part Number	Pressure Setting (PSI)	Flow Capacity (SCFM/Air)	Inlet Connection (M.NPT)	Height A	Wrenching Hex B
UA3149A303	303	9,805*	2½"	10½"	4⅜"
UA3149A330	330	10,188*			
UA3149A358	358	11,601*			

\*Capacity certified by National Board of Boiler and Pressure Vessel Inspectors at 10% above set pressure.

# Brass Pipe Caps

### Application

For capping cryogenic tank piping or gas pipelines.

### Features

- Machined from brass.
- For 600 psig maximum working pressure service.
- Part number stamped on cap.
- Cleaned for oxygen per CGA G-4.1.

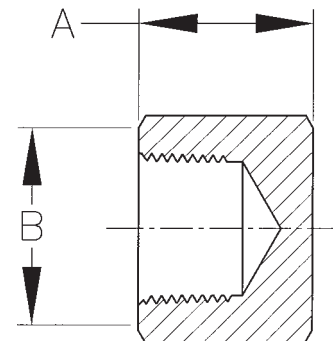

### Ordering Information

Part Number	Thread Connections	Dim. A	Dim. B	Dim. C
CAP750	¾" Female NPT	1.250"	1.313"	1.313"
CAP1000	1" Female NPT	1.500"	1.750"	1.750"
CAP1500	1 ½" Female NPT	1.750"	2.375"	2.375"
CAP2000	2" Female NPT	2.000"	3.250"	3.250"