

Needle Valves

CMM250 Series and CFF250 Series

Application

Ideal for use as a gauge isolation valve or applications requiring accurate throttling of pressure.

Features

- Compact design provides easy installation.
- Fine stem threading and long taper allow precise metering and leak-free shut-off.
- Internal stop prevents the stem from being accidentally unscrewed from the body.
- Rugged forged brass bodies withstand higher pressures.
- Unbreakable brass handwheel.
- Valves come equipped for panel mounting.
- Working temperature range is -40°F to +165°F.
- Maximum operating pressure: 2000 psig air.
- Cleaned for oxygen service per CGA G-4.1.
- Female ports available - consult factory.

Materials

Body	ASTM B283 Brass
Stem	Brass
Knob	Brass
Bonnet Nut	Brass
Panel Mount Nut (Optional)	Brass
Set Screw	Steel
Stem Packing	PTFE with Brass Gland

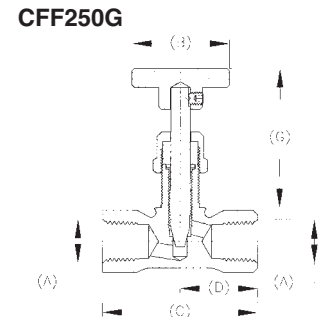
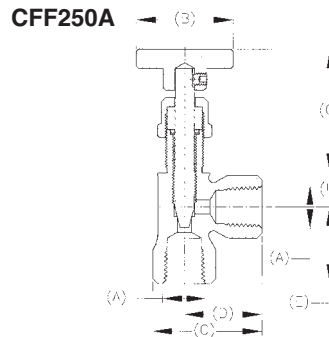
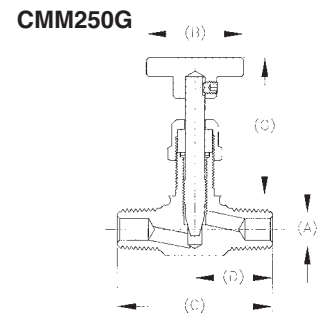
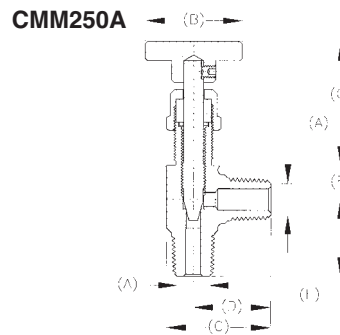

Part Number	A (NPT)	B (In.)	C (In.)	D (In.)	E (In.)	F (In.)	G (In.) Open	G (In.) Closed	C _v
CMM250A	1/4	1 1/4	1 11/32	1	1	7/16	2 5/32	1 19/32	.7
CMM250G	1/4	1 1/4	2	7/8		7/16	2 5/32	1 19/32	.5
CFF250A	1/4	1 1/4	1 13/32	3/4	1	7/16	2 3/16	1 5/8	.7
CFF250G	1/4	1 1/4	2	1		7/16	2 3/8	1 13/16	.5