

# Short Stem Cryogenic Valves

## T9450 Series T9460 Series

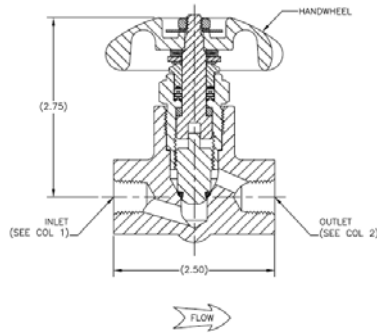

### Ordering Information

Part Number	Inlet	Outlet	Orifice A	Length B	Height (Approx.) C	Tube D	Cv Factor
T9452	1/4" F.NPT	1/4" F.NPT	.250	2 1/2"	2 3/4"	None	.72
T9453	3/8" F.NPT	3/8" F.NPT	.406				1.08
T9454	1/2" F.NPT	1/2" F.NPT	.406				1.10
T9464CA	.675 Tube	3/8" F.NPT	.406	2 1/2"	2 3/4"	1 1/8"	1.08
T9464DA						2 1/8"	
T9464ADA						3 3/8"	

### Application

The T9450 and T9460 series valves are designed for use on portable cryogenic cylinders and other in-line shut-off valve applications. Approved for TPED in accordance with EN1626.

### Features

- Spring loaded stem seal automatically adjusts for any gasket wear, eliminating the need to constantly retighten the packing nut.
- Non-rising stem and low profile allow the valve to fit into tight areas and still provide easy access.
- Unique pressure-sealed moisture barrier helps prevent freeze up at cryogenic temperatures.
- Conical swivel seal design helps prevent seat galling from over torquing.
- Cleaned for liquid oxygen service per CGA G-4.1.
- Maximum working pressure is 600 PSIG.
- Working temperature range is -320°F to +165°F.

### Materials

Body.....	Brass
Bonnet.....	Brass
Seat Disc.....	CTFE
Stem Seal Gasket.....	PTFE
Handwheel.....	Aluminum
Spring.....	Stainless Steel
Upper Stem.....	Brass
Lower Stem.....	Manganese Bronze

# Extended Stem Retrofit Kits

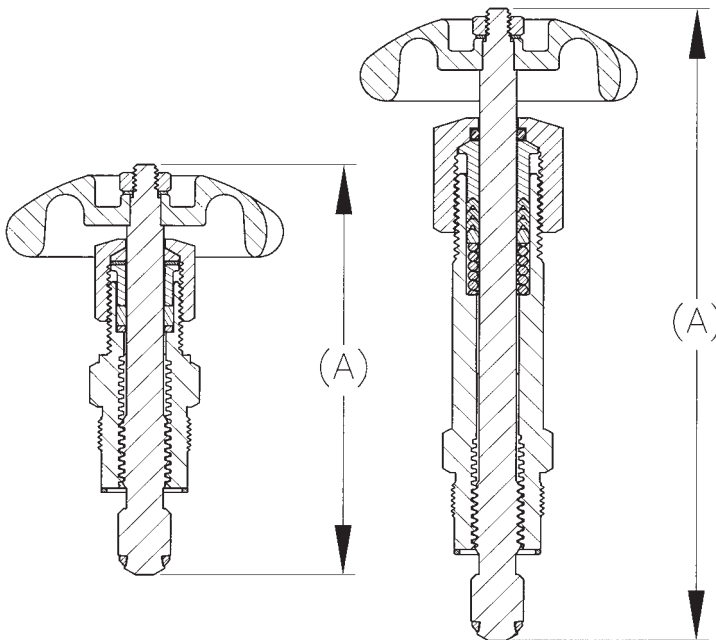

### Application

These retrofit kits can be used to convert the 9450 and 9460 series short stem shut off valves into extended stem style. The conversion can be done without removing the valve from your system. Available in two stem lengths. All kits are oxygen cleaned and packaged per CGA G-4.1.

### Materials

Bonnet.....	Brass
Seat Disc.....	CTFE
Handwheel.....	Aluminum
Packing.....	PTFE
Stem.....	Stainless Steel
Stem Seal Gasket.....	PTFE

### Ordering Information

Part Number	Stem Length A	Style
ES8450R	4"	Extended Stem, Std. Bonnet, Manual Packing
BK9450R	6.5"	Extended Bonnet and Stem, Spring Loaded Packing