

Cylinder Valve for Liquid Withdrawal 9107K8A

Application

Equipped with excess flow valves and liquid withdrawal tubes, they are designed for liquid withdrawal of DOT cylinders up to 100 lbs. propane capacity. They are most often used with heavy BTU loads found in industrial uses.

Features

- O-ring stem seal design.
- Nylon tapered seat disc for positive closure.
- Self-tapping screw secures handwheel to stem and reduces possibility of handwheel vibrating loose while in transit.
- Features ball check excess flow valve.
- Furnished with 1/2" O.D. brass withdrawal tube with "T" dimension of 44".

Materials

Body Forged Brass
 Handwheel..... Aluminum Die Cast
 Seat Disc Nylon
 O-Rings Resilient Rubber
 Relief Spring Stainless Steel
 Stem Brass

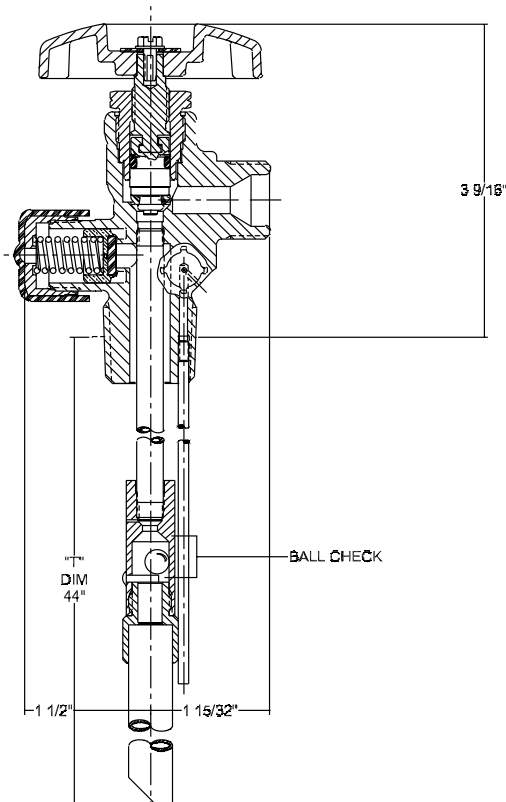
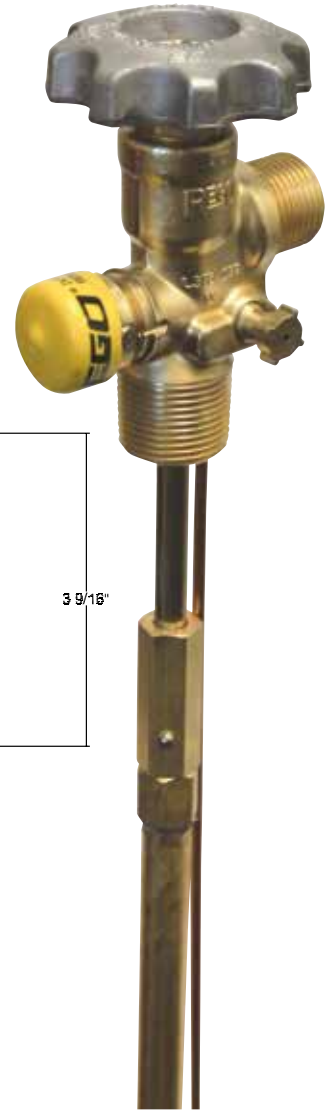

9107K8A



Ordering Information

Part Number	Container Connection	Service Connection	Fixed Liquid Level Vent Valve	Dip Tube Length	Liquid Withdrawal Tube Length
*9107K8A	3/4" M. NGT	CGA 555	Included	11.6"	44"

* 72 Orifice low emission version is also available.

Pressure Relief Valve Setting	For Use in Cylinders w/Propane Capacity Up To:	Approximate Filling Rate Liquid Flow, GPM				Closing Flow (L.P-Gas) *		
		Pressure Drop Across Valves				Vapor		Liquid
		10 PSIG	25 PSIG	50 PSIG	100 PSIG	25 PSIG Inlet	100 PSIG Inlet	
375 PSIG	100 lbs.	3.3	5.4	7.7	11.1	525 SCFH	1,000 SCFH	1.7 GPM

*Closing flows based on 3/8" O.D. withdrawal tube 44" long or less attached.

IMPORTANT: 1/4" O.D. pigtails or POL connections for 1/4" O.D. pigtails should not be used with these valves.

NOTES: To ensure proper functioning and maximum protection from excess flow valves, the cylinder valve should be fully opened and backseated when in use. These valves incorporate an excess flow valve. Refer to L-500 / Section F, for complete information regarding selection, operation and testing of excess flow valves.