

Multipurpose Valves for Liquid Withdrawal of LP-Gas and NH₃ Containers

A8017D & A8020D

Application

Designed especially for use as a high capacity liquid withdrawal valve on LP-Gas and anhydrous ammonia containers.

These valves incorporate an integral excess flow valve. When product is required, the valve must be completely open and backseated to allow the excess flow valve to function properly as explained in the excess flow valve section of this catalog.

The A8017DH is equipped with a soft seated automatic differential back pressure check valve in the seat disc assembly. This allows any pressure build up in the liquid transfer line in excess of 10-15 psig above the container pressure to flow back into the container. The transfer hose is protected against excessive liquid or vapor pressure entrapment, which adds materially to the useful life of flexible hose. In addition to increasing hose service life, the equalizing valve adds substantially to the operating safety of liquid transfer systems.

Features

- Positive-acting excess flow valve opens for maximum flow at minimum pressure drop when filling — regardless of the type of coupling in which the valve is installed.
- Excess flow seat is fully contained in the tank coupling for maximum protection in the event of external damage to the valve.
- Resilient seat disc assembly is fully contained on three sides for bubble-tight shut-off and long service life.
- "V"-ring spring loaded stem seal design requires no repacking or field adjustment.
- A8017DH has two plugged ¼" NPT ports, one on the top and the other on the side, accommodate either a vent valve or hydrostatic relief valve.
- A8020D has a plugged ¼" NPT port that accommodates vent valve, hydrostatic relief valve, or pressure gauge.
- A8017DH incorporates an automatic back check valve built into the shut-off valve, eliminating the need for a separate hydrostatic relief valve.

Materials

| | |
|-------------------------|--------------------------------------|
| Body | Ductile Iron |
| Bonnet | Steel |
| Stem | Stainless Steel |
| Seat Disc | Resilient Synthetic Rubber |
| "V"-Rings | Teflon |
| Excess Flow Valve | Stainless Steel - Steel Body Springs |
| Stem Seal | Stainless Steel |

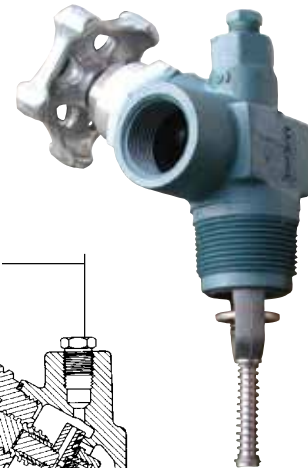

A8017DP

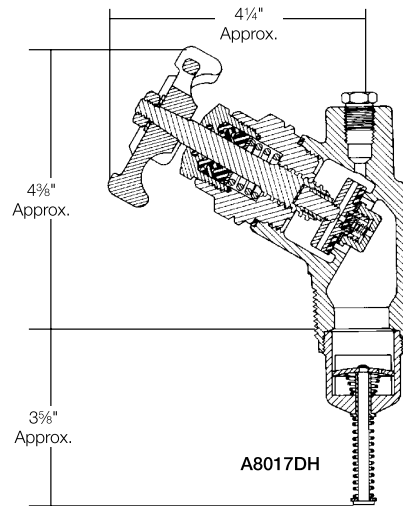

A8017DH

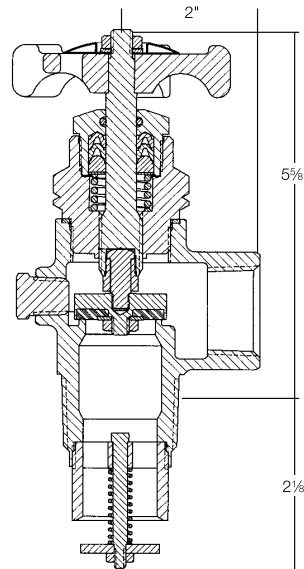

A8020D



Ordering Information

| Part Number | Inlet Connection (M. NPT) | Outlet Connection (F. NPT) | Approximate Excess Flow Liquid Closing Flow** (GPM/Propane) | Accessories | |
|-------------|---------------------------|----------------------------|---|--------------------------|------------|
| | | | | Hydrostatic Relief Valve | Vent Valve |
| A8017DH* | 1 1/4" | 1" | 49 | Not Required | TSS3169 |
| A8017DP | | | 55 | | |
| A8017DLP | 1 1/4" | 1" | 49 | SS8001J | TSS3169 |
| A8020D | | | 78 | SS8001J | TSS3169 |

* Built-in back pressure check valve incorporated into shut-off valve.

** Determined at 11.5 to 13.5 PSIG differential for 3/4" outlet and 9 to 12 PSIG differential for 1" outlet. For NH₃ flow, multiply by .90.