

2" & 3" Globe/Angle valves with Built-in Automatic Back Check HA7513AP/HA7514AP and HA7517AP/HA7518AP

Application

Designed for use in conjunction with our 6588LE and 6589LE low emission filler valves installed on bobtails and transports. The valves are designed to stop flow out of the container when the hand-wheel is closed. They incorporate an automatic integral back check that is designed to allow flow back into the container to prevent liquid from becoming trapped between the 6588/89LE and the closed globe/angle valve.

Features

- V-ring spring loaded pressure stem seal provides for leak-proof operation. No packing to retighten or replace.
- Circular bridge in globe design and a dropped seat in the angle design achieve greater flow with less pressure drop.
- Swivel seat disc assembly minimizes wear which provides for good alignment and long seat life.
- ¼" F.NPT plugged holes on upstream and downstream sides of the valve.
- Heavy duty rolled ACME stem threads provide quick action and long service life.
- Seat Disc assembly incorporates an automatic back check valve, eliminating the need for a separate hydrostatic relief valve.

Materials

Body Ductile Iron
 Stem Stainless Steel
 Seat Stainless Steel
 Seat Disc Synthetic Rubber
 Return Spring Stainless Steel

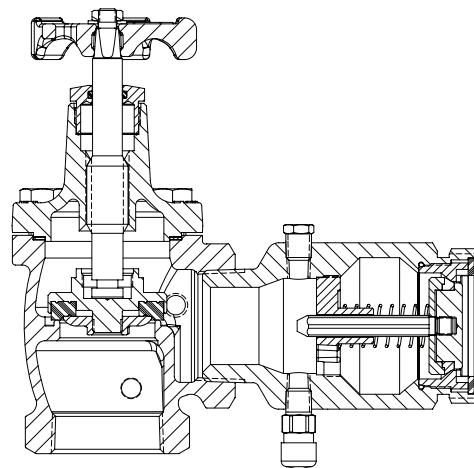
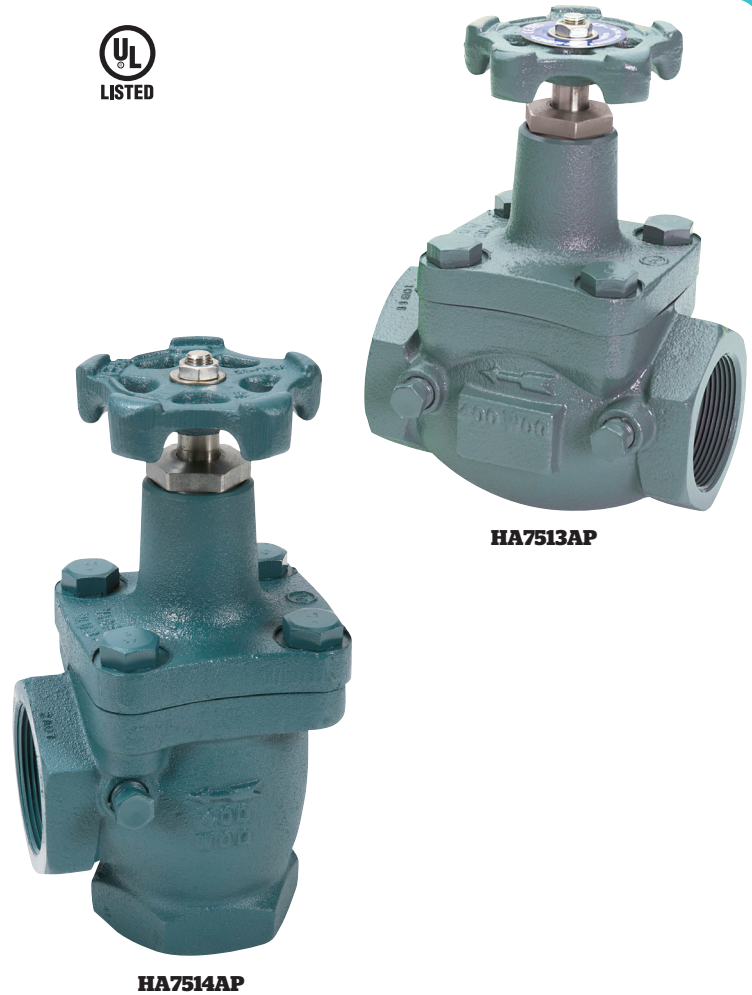

Ordering Information

Part Number		Inlet/Outlet Connection	Port Diameter	Flow at 1 PSIG Pressure drop GPM Propane	
Globe	Angle			Globe	Angle
HA7513AP	HA7514AP	2" -FNPT	2"	75.0	88.5
HA7517AP	HA7518AP	3" -FNPT	3½"	197.0	303.0