

1 1/4" Threaded Internal Valve for Small Capacity Pumping Systems and Bobtail Vapor Equalization A3209D & A3209DT Series

Application

Designed primarily for use with LP-Gas and anhydrous ammonia as a main valve on small capacity pumping systems, NH3 nurse tanks and in-line installations. It may also be installed in the vapor equalizing opening on bobtail delivery trucks. Installation is quick and easy, and it fits in both full and half couplings, as well as, in-line applications. The valve may be actuated manually by hand or cable.

Features

- Valve is compact, with one piece body construction.
- Spring loaded V-packing with heavy duty wiper ring on operating shaft for dependable leak-free construction.
- Nylon bearing supported operating shaft provides smooth, easy operation.
- Simple operating lever allows for easy connection of cable controls.
- Built in excess flow valve
- Return spring forces the valve to the closed position when the lever is released.
- All critical operating components are located in the valve body and inside the container coupling for maximum protection against damage.
- Midway stem position allows for quick pressure equalization.
- Equipped with 212° F, UL listed fuse link for thermal protection.

Materials

Body Ductile Iron
 Operating Lever..... Cadmium Plated Carbon Steel
 Stem Stainless Steel
 Springs Stainless Steel
 Seat Disc Resilient Synthetic Rubber
 Shaft Bearing..... Nylon

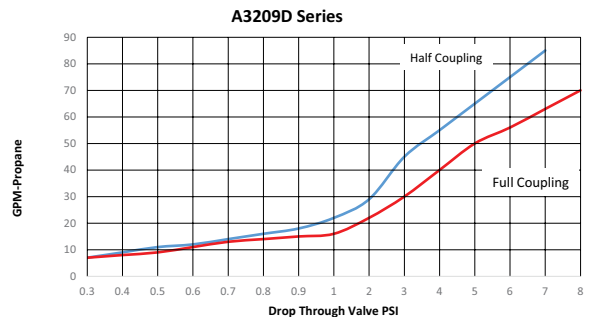
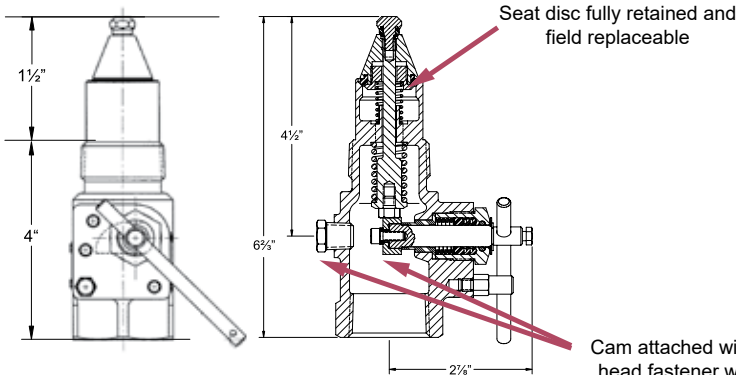
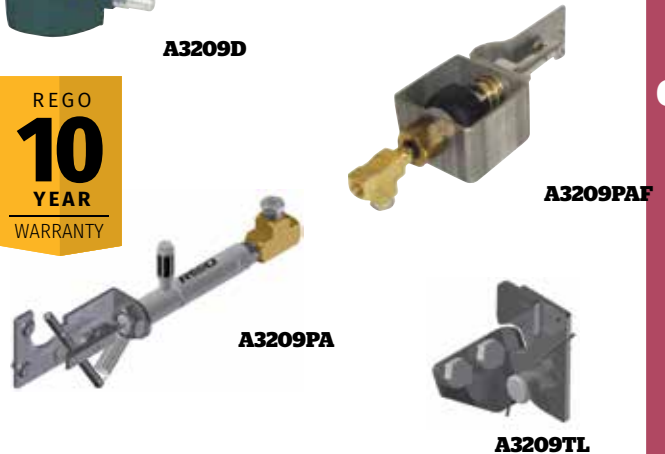
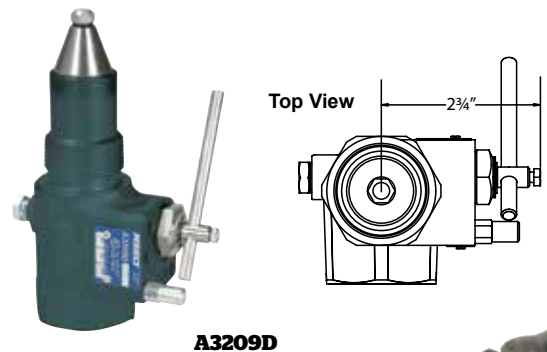
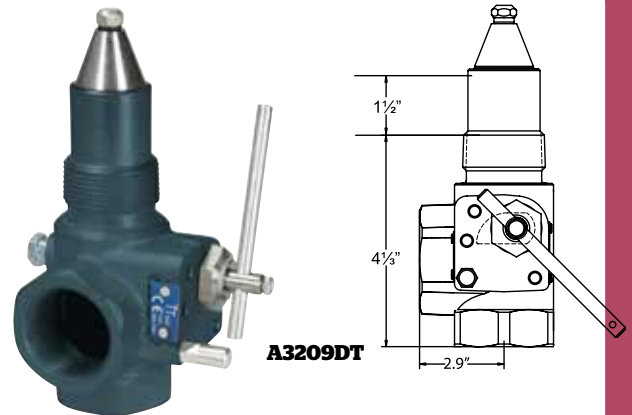

Ordering Information

Part Number	Inlet Connection M. NPT	Outlet Connection F. NPT	Closing Flow		LP-Gas Vapor Capacity** (SCFH/Propane)		Accessories		
			LP-Gas	NH3	25 PSIG	100 PSIG	Thermal Latch	Pneumatic Actuators	Electric Actuators
A3209D050	1 1/4"	1 1/4"	50	45	13,300	22,900	A3209TL	A3209PA A3209PAF	A3209EA
A3209D080	1 1/4"	1 1/4"	80	72	15,700	26,700			
A3209DT050*	1 1/4"	1 1/4"	50	45	13,300	22,900			
A3209DT080*	1 1/4"	1 1/4"	80	72	15,700	26,700			

* T-Body Design

1 1/4" Threaded Internal Valve with Electric Actuator for Small Capacity Pumping Systems and Bobtail Vapor Equalization EA3209E Series

Application

Designed primarily for use with LP-Gas and anhydrous ammonia as a main valve on small capacity pumping systems, NH3 nurse tanks and in-line installations. It may also be installed in the vapor equalizing opening on bobtail delivery trucks. Installation is quick and easy, and it fits in both full and half couplings, as well as, in-line applications.



EA3209D Series

Features

- One piece body construction.
- Spring loaded V-packing with heavy duty wiper ring on operating shaft for dependable leak-free construction.
- Nylon bearing supported operating shaft provides smooth, easy operation.
- Excess flow valve feature
- Return spring forces the valve lever to the closed position when the power is de-energized.
- All critical operating components are located in the valve body and inside the container coupling for maximum protection against damage.
- Midway stem position (rapid bleed) allows for quick pressure equalization.
- Equipped with 212° F, UL listed fuse link for thermal protection.
- Provides a convenient means of electrically opening and closing the valve from a remote location.
- CSA/UL rated Explosion Proof Enclosure on the actuator.
- Class I, Div 1 Groups B, C, D, / T6
- 12-24VDC
- Internal Valve is UL Listed and TPED Certified
- Electric Actuator is ATEX Certified

Materials

Body	Ductile Iron
Operating Lever	Cadmium Plated Carbon Steel
Stem	Stainless Steel
Springs	Stainless Steel
Seat Disc	Resilient Synthetic Rubber
Shaft Bearing	Nylon

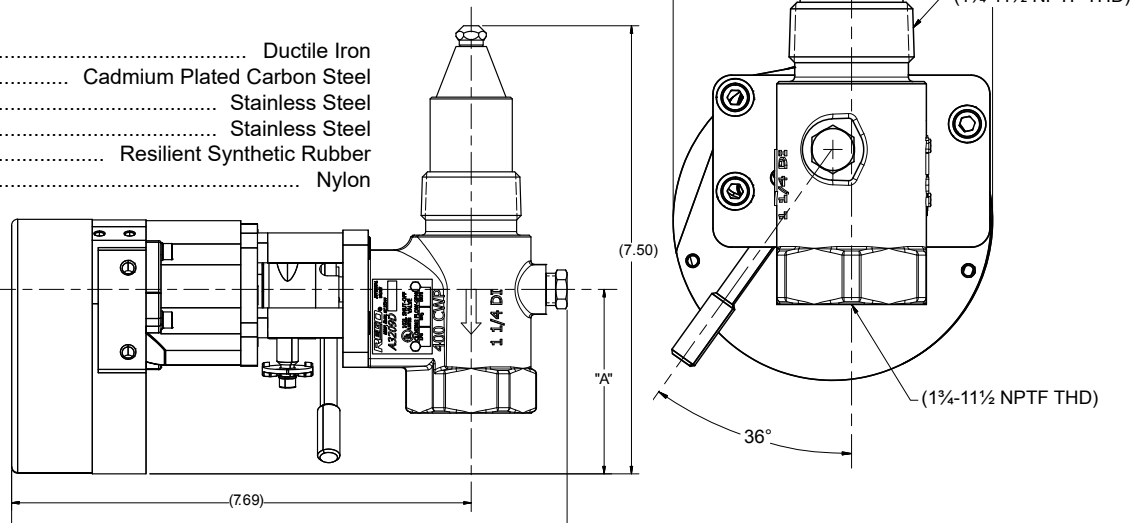

Ordering Information

Part Number	Inlet Connection M. NPT	Outlet Connection F. NPT	Voltages	Closing Flow		LP-Gas Vapor Capacity** (SCFH/ Propane)	
				LP-Gas	NH3	25 PSIG	100 PSIG
EA3209D050	1 1/4"	1 1/4"	12/24 VDC	50	45	13,300	22,900
EA3209D080	1 1/4"	1 1/4"		80	72	15,700	26,700
EA3209DT050*	1 1/4"	1 1/4"		50	45	13,300	22,900
EA3209DT080*	1 1/4"	1 1/4"		80	72	15,700	26,700

* T-Body Design

**Data for full flow in half coupling.

