

Fixed Liquid Level Gauges 3165 Series and TA3169F

Application

Especially designed to provide a visible warning when containers are filled to the maximum permitted filling level. At the start of the filling operation, with the vent stem opened, the valve discharges vapor. When the maximum permitted filling level is reached, the valve discharges liquid. The 3165CF*, 3165CF12.0, 3165SF12.0 and TA3169F12.0 incorporate a No 54 drill orifice; the 3165DF* and 3165DF12.0 incorporate a No 72 drill orifice. They all are normally furnished with a 12" 3/16" OD dip tube.

An optional instruction plate with "Stop Filling When Liquid Appears" may be ordered for use with these valves.



3165CF12.0
3165DF12.0



TA3169F12.0



Materials

Body (3165)..... Brass
 Body (TA3169)..... Stainless Steel
 Seat Disc (3165)..... Resilient Synthetic Rubber
 Seat Disc (TA3169) Teflon

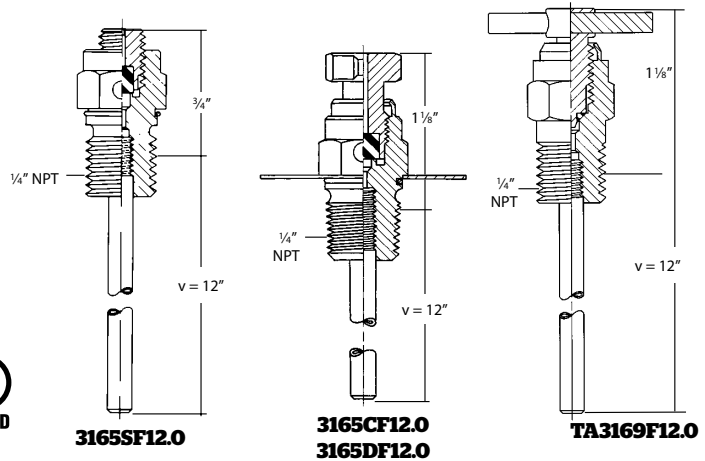

Ordering Information

Part Number	Service	Connection	Actuation	Dip Tube Length	Accessories
					Warning Plate Kit
3165CF*	LP-Gas Only	1/4" M. NPT	Ribbed	*	2550-40P
3165DF*				12"	
3165CF12.0					
3165DF12.0					
3165SF12.0					
TA3169F12.0	LP-Gas & NH3		Tee Handle		