

Pneumatic Rotary Actuators

A3200A Series

Application

These actuators provide the opening and closing of valves in hard to reach or remote areas. Useful on bobtail delivery trucks, transport trailers, and bulk plants, their remote control can safely be piped to almost any location.

Features & Benefits

- For use with nitrogen or compressed air
- Compact size with same power and torque for easier placement
- Low-friction construction with self-lubricated strips prevents the actuator from sticking even after long periods of inactivity
- Double-acting movement powerful in both opening and closing for true automated control
- Wear items, including pins, slots and bushings made of hardened steel for the utmost durability and longevity
- Scotch yoke design turns linear motion of piston into rotary motion for valve actuation and eliminates rack and pinion, teeth and gears that are susceptible to stripping, providing a lighter weight, smaller product with longer life
- Rolled cylinder provides a super smooth surface finish for less wear and longer life.
- Expected service life 1,500,000+ cycles
- Inlet tee fitted with 1/4" F. NPT outlet and 212° F thermal fuse plug

Materials

Body Aluminum
 Springs Stainless
 Stem Seals Nitrile



A3217LOA

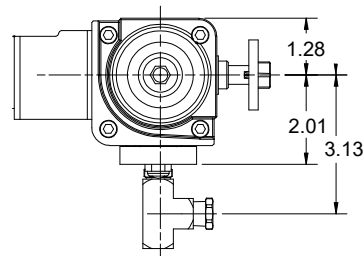
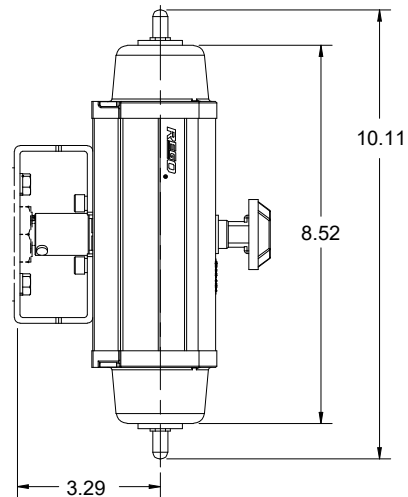

Ordering Information

| Part Number | For Internal Valve Series | Recommended Supply Pressure | Inlet Connection | Outlet Connection |
|-------------|---------------------------|-----------------------------|------------------|-------------------|
| A3209OA | A3209D | 90-120 psi (6.2-8.4 bar) | 1/4" F. NPT* | Filtered Vent |
| | A3211D | | | |
| A3212OA | A3212R | | | |
| A3213OA | A3213D | | | |
| A3217LOA | A3217AL | | | |
| | A3217DAL | | | |
| A3217ROA | A3217AR | | | |
| | A3217DAR | | | |

*1/8" F. NPT Inlet Connection to Rotary Actuator tee provided for 1/4" F. NPT Connection